



GLOBALTECH

Tripods

Studio Equipment

Grip Accessories

Globaltech Trading GmbH

Bodenfeldstrasse 37

8906 Bonstetten

Switzerland

Tel. +41 44 737 4000

Fax +41 44 737 4001

info@globaltech.ch

www.globaltech.ch

2008/2009





GLOBALTECH

Tripods 4

Cameraheads 6

Background equipment 7

Lighttables 8

Reflectors 9

Lightingsupports 10

Studio accessories 11

Ceiling rail system 14

Lighting 15



GLOBALTECH

Tripods

-  3110g
-  1550mm
-  630mm
-  690mm
-  25.5mm
-  4kg



A-1060
3-Section Alu leg tripod with head
and bag
Height 0.53-1.52 meter

-  5050g
-  1800mm
-  760mm
-  820mm
-  34.5mm
-  6kg



A-1070
3 Section Alu leg tripod
with bag
Height 0.55-1.8 meter



With tripod bag

Tripods

-  1850g
-  1490mm
-  80mm
-  63 cm
-  26.5mm
-  5kg

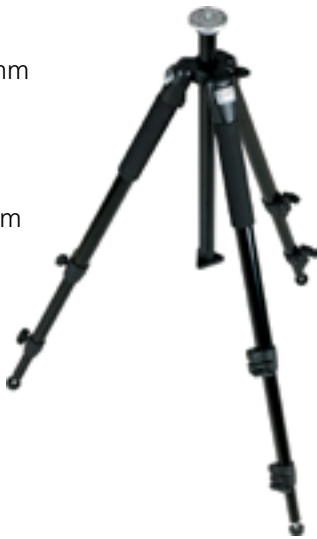

A-1080
MINI CLASSIC tripod height 0.55-1.49 meter

-  2450g
-  1650mm
-  320mm
-  64 cm
-  30mm
-  8kg



A-1090
MINI CLASSIC Tripod with crank height 0.64-1.4 meter

A-1500, A-1520, A-1540
Carbon-Fiber tripod
with bag
Height 0.38-1.57 meter



	A-1500	A-1520	A-1540
	1180g	1540g	1860g
	1350mm	1480mm	1570mm
	360mm	400mm	380mm
	530mm	570mm	610mm
	24mm	28mm	32mm
	8kg	10kg	12kg

-  1070g
-  520mm
-  50 kg

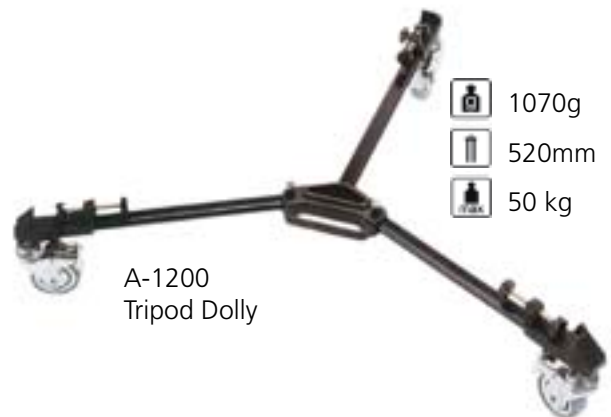

A-1200
Tripod Dolly



A-1300
Plattform
Size 35.6 x 25.4cm
Weight 1.1kg



GLOBALTECH

Cameraheads



- 1550g
- 7.5kg
- 180mm

B-2040
Pan tilt head
with quick exchange unit



- 470g
- 6kg
- 105mm

B-2130
PRO ballhead



- 1000g
- 6kg
- 140mm

B-2030
Pan tilt head
with quick exchange unit



- 760g
- 8kg
- 132mm

B-2500
Magnesium Alloy Camera head
with quick exchange unit



- 480g
- 6kg
- 100mm

B-2120
Compact ballhead



- 90g

B-2300
Extra plate for B-2040



- 40g

B-2310
Extra plate for B-2120



- 70g

B-2320
Extra plate for B-2130

Background equipment



ncl. chain and weight

 0.95kg



C-3030
Single brackets

 1.0kg



C-3020
Tripple brackets
one pair

 1.76kg





C-3100
System compl. with 3 x C-3010
and 1 x C-3020

 4.6kg

C-3150
Moveable background support, black

 1.19 - 2.84m

 2.1 - 3.15m

 4.0kg





GLOBALTECH

Lighttables

D-4010
Background table small
Plastic board 60x130cm
Max lenght 120cm
Width 60cm
Poles Ø 19mm
Carring bag included
Weight 4.4kg

D-4015
Board to D-4010 only
Weight 1.4kg

D-4020
Background table medium
Plastic board 100x200cm
Max lenght 180cm
Width 100cm
Poles Ø 25/31,5mm
Carring bag included
Weight 13kg

D-4025
Board to D-4020 only

D-4100
Lighttunnel to table
D-4010
Weight 0.8kg

D-4110
Lighttunnel to table
D-4020
Weight 1.4kg



Reflectors



Double sided reflectors
 D-4600 sunlight / white
 D-4630 gold / silver
 D-4670 silver / white

circular Ø 105 cm
 circular Ø 105 cm
 circular Ø 105 cm

Multi colour reflectors
 D-4900 translucent / silver / gold / white / black
 D-4920 translucent / silver / gold / white / black

circular Ø 81 cm
 circular Ø 107 cm

Double sided reflectors
 D-4710 gold / silver
 D-4730 sunlight / white
 D-4750 silver / white

oval 102x166 cm
 oval 126x152 cm
 oval 102x166 cm

Diffusers
 D-4850 translucent
 D-4860 translucent

oval 102x166 cm
 oval 157x190 cm

Multi colour reflectors
 D-4940 translucent / silver / gold / white / black
 D-4950 translucent / silver / gold / white / black

oval 91x122 cm
 oval 102x166 cm



D-4970
 Holder for reflectors 63-138 cm
 with clamp for Ø 19/22/25/28 mm



D-4500
 Moveable reflector
 translucent
 Frame dimension 1.4x2.0 m
 Maximum height 3.05 m
 Weight 4 kg

D-4510
 Reflector kit black / silver



D-4400
 Light tent
 60x60x60cm
 Weight 0.85kg

D-4410
 Light tent
 75x75x75cm
 Weight 1.19kg



GLOBALTECH

Lightstands

E-5010 improved quality
Aluminium lightstand 2.4 Meter
air cushioned black
Max hight 240 cm
Min hight 78 cm
Spread Ø 94 cm
Diam. of legs 19 mm
Poles Ø16/19/22/25 mm
Weight 1.1 kg

E-5020 improved quality
Aluminium lightstand 3.0 Meter
air cushioned black
Max hight 300 cm
Min hight 99 cm
Spread Ø 98 cm
Diam. of legs 19 mm
Poles Ø16/19/22/25 mm
Weight 1.3 kg

E-5030
Lightstand grand 3.9 Meter
air cushioned black
Max hight 390 cm
Min hight 128 cm
Spread Ø 130 cm
Diam. of legs 25 mm
Poles Ø25/28/31.5/35 mm
Weight 2.5 kg

E-5030
Lightstand grand 3.9 Meter
air cushioned black

E-5020 improved quality
Lightstand 3.05 Meter
air cushioned black

E-5010 improved quality
Lightstand 2.4 Meter
air cushioned black



E-5210
Backlight-kit compl
Weight 4.0 kg
Height 40 - 70 cm
with adaptor
for low positions



E-5110
Lightboom
with stand incl. bag
and sandbag
Boomlength 120 - 210 cm
Weight total 7.8 kg



E-5140
Counterweight
Weight 5 kg
Ø 32 mm



E-5130
Sandbag
Weight 100 gr.



E-5310
Wall boom 1.25 Meter
Max load 8 kg
Weight 2.9 kg



E-5400
Set of casters for lightstand
for leg Ø 19mm
Fits to: E-5010, E-5020
Weight 0.64 kg



E-5410
Set of casters for lightstand
for leg Ø 25mm
Fits to: E-5030, E-5110,
C-3150
Weight 0.84 kg

Studio accessories



F-6010
Universal clamp
Weight 0.48 kg



F-6020
Double universal clamp
Weight 1.0 kg



F-6030
C-Clamp
Weight 0.2 kg



F-6040
C-Clamp with spigot adaptor
vertical
Weight 0.35 kg



F-6050
C-Clamp with spigot adaptor
Weight 0.22 kg



F-6060
C-Clamp with hook
Weight 0.19 kg



F-6070
C-Clamp with spigot adaptor
Weight 0.22 kg



F-6080
C-Clamp with ballhead
Weight 0.27 kg



F-6090
C-Clamp with extension rod
Weight 0.2 kg



F-6100
Double C-Clamp
Weight 0.36 kg



F-6150
Clip
Weight 0.11 kg



F-6160
Clip with spigot
Weight 0.19 kg



F-6200
Tilting bracket with umbrella
holder
Weight 0.2 kg



F-6210
Adjustable clamp
Ø19/22/25/29mm



F-6230
Adjustable clamp with PRO CLAMP
Ø19/22/25/28mm

F-6220
Adjustable clamp
Ø16/20/28/31.5mm
Weight 0.4 kg

F-6240
Adjustable clamp with PRO CLAMP
Ø16/20/28/31.5mm
Weight 0.73 kg



F-6340
Full metal heavy duty table clamp
Ø25/19/16/8mm
Weight 0.85 kg



F-6350
Full metal heavy duty universal clamp
Ø25/19/16/8mm
Weight 0.64 kg



GLOBALTECH

Studio accessories



F-6300
Ceiling/ wall spigot mount
Weight 0.15 kg



F-6310
Ceiling/ wall mount with spigot
Weight 0.2 kg



F-6400
Flex arm 54 cm with 1/4" and 3/8" thread male
Weight 0.53 kg

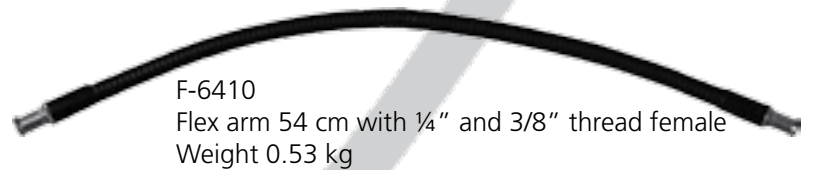

F-6410
Flex arm 54 cm with 1/4" and 3/8" thread female
Weight 0.53 kg

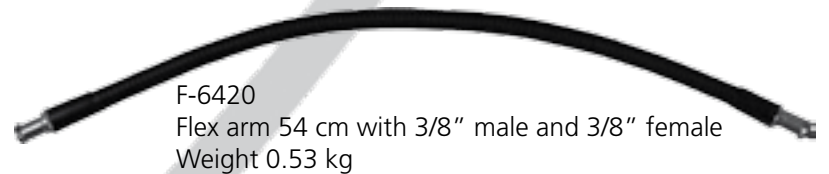

F-6420
Flex arm 54 cm with 3/8" male and 3/8" female
Weight 0.53 kg



F-6500
Flex arm 20 cm with clip and spigot
Weight 0.12 kg



F-6510
Flex arm 20 cm with clip and base
Weight 0.76 kg



F-6520
Flex arm 54 cm with clip and base
Weight 1.28 kg



F-6550
Base plate 25x20x2cm
Weight 2.0 kg

Studio accessories



F-6600
Extension rod 40 cm female
Weight 0.3 kg



F-6630
Extension rod 15cm male
Weight 0.25 kg



F-6700
Spigot 16 mm 1/4" and 3/8" thread
male 54 mm
Weight 0.07 kg

F-6610
Extension rod 56 cm female
Weight 0.33 kg

F-6640
Extension rod telescopic 45-77 cm
Weight 0.4 kg



F-6620
Extension rod 76 cm female
Weight 0.36 kg

F-6650
Extension rod telescopic 50-95 cm
Weight 0.45 kg

F-6710
Spigot 16 mm 3/8" and 1/4" thread
male 32 mm
Weight 0.04 kg



F-6720
Spigot 16 mm 3/8" and 1/4" thread
female
Weight 0.03 kg



F-6730
Spigot Threads 3/8" female and
1/4" male
Weight 0.05 kg



F-6740
Spigot 16mm 3/8" male and 1/4"
female
Weight 0.05 kg

F-6800 Table top reflector set
For multiple use with base or table clamp



with table clamp

- Contains
- 1 F-6410 Flex arm
 - 1 F-6160 Clip with spigot
 - 1 F-6070 C-Clamp with spigot adaptor
 - 1 Base 2.0 kg
 - 1 Reflector board 35x30cm silver/white
- Weight 3.9 kg



with base



GLOBALTECH

Ceiling rail system

G-7010
System compl 3x4 meter with 4 pantographs

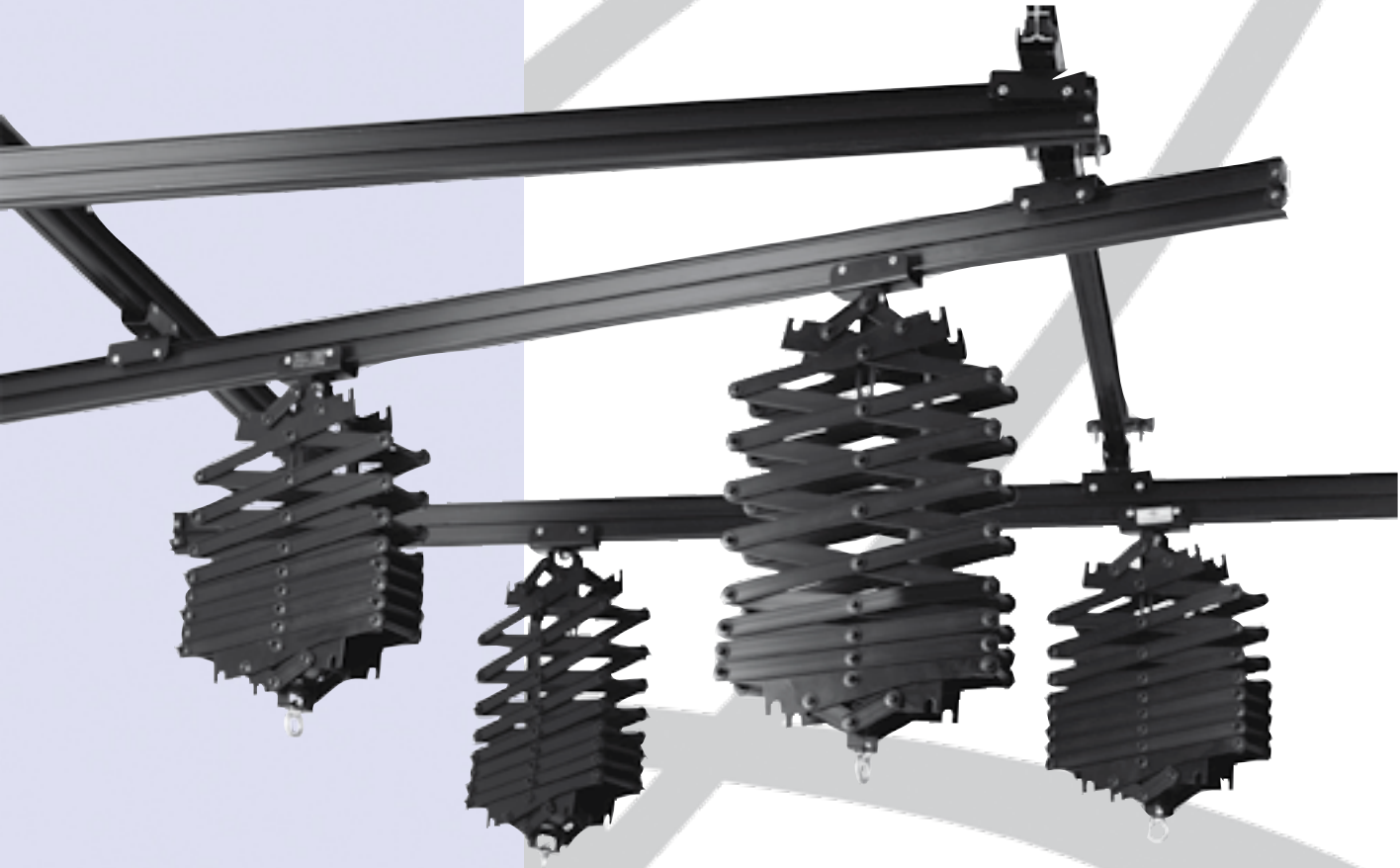

G-7020
Pantograph 2 meter
Load adjustable 0,5 - 7,0 kg

G-7030
Ceiling rail 3 meter

G-7040
Ceiling rail 4 meter

G-7050
Double pulley

G-7070
Cable carriage

G-7080
End stop

G-7090
Bracket

Lighting

H-9100 Digital Internet Flash Kit



- 3 Digital Flash units 180WS
- 1 Softbox 40x60 cm
- 1 Octagonal Softbox
- 1 Honey Comb
- 1 Carrying bag for Flash units
- 3 Alu light stands 200 cm
- 1 Bag for light stands

Technical Data

Flash Energy	180Ws
F-stop	42GN
Charging time	1.2-2.2s
Power regulate	1/4- 1/1
Flash duration	1/1000 – 1/1600s
Colour temperature	5200 -5500° K
Modelling lamp	AC220/35W
Power source	220V 50/60Hz 5A

- 1 Background table
- Plastic board 60x130 cm
- Incl. carrying bag
- D-4010

H-9110 Digital Internet Flash Kit only

- H-9210 Spare Flashtube
- H-9310 Spare Modelling lamp





GLOBALTECH

Globaltech Trading GmbH

Bodenfeldstrasse 37

8906 Bonstetten

Switzerland

Tel. +41 44 737 4000

Fax +41 44 737 4001

info@globaltech.ch

www.globaltech.ch

Your dealer: